

# SPX KENT-MOORE

## J 42385-100 CYLINDER HEAD/MAIN BEARING CAP BOLT THREAD REPAIR KIT TIMESERT®

### KIT CONTENTS

INSERT SIZE	INSERT (QTY.)	STEP DRILL	TAP	DRIVER
M11 x 2.0 x 30mm (Head Bolt)	J 42385-108 (10)	J 42385-105	J 42385-106	J 42385-107
M10 x 2.0 x 22mm (Main Bearing Bolt)	J 42385-104 (4)	J 42385-101*	J 42385-102	J 42385-103
LOCTITE #277 (J 42385-109) DRIVER OIL (J 42385-110)	*Use with J 42385-311 Stop Collar for starter mount holes (see J 42385-200 Kit for other required tools).			

### OTHER ITEMS REQUIRED (From J 42385-300 Fixtures and Hardware Kit)

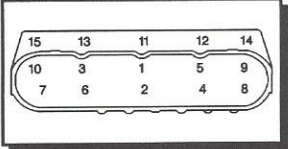
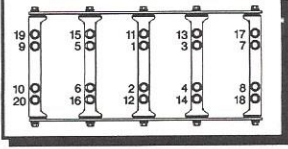
CYLINDER HEAD BOLT HOLES	MAIN BEARING CAP BOLT HOLES
J 42385-301 ..... Fixture J 42385-302 ..... Bushing J 42385-303 ..... Alignment Pin J 42385-304 ..... Long Bolts (3) J 42385-305 ..... Short Bolt (1) J 42385-315 ..... Sleeve* (*use with J 42385-105 Step Drill for shallow holes only)	J 42385-306 ..... Fixture J 42385-307 ..... Bushing J 42385-308 ..... Alignment Pin J 42385-309 ..... Long Bolts (2) J 42385-310 ..... Short Bolts (2) J 42385-316 ..... Sleeve* (*use with J 42385-101 Step Drill for shallow holes only)
<b>HOLE LOCATIONS</b> Shallow Holes: 9, 10 	<b>HOLE LOCATIONS</b> Shallow Holes: 11, 12, 13, 14, 15, 16, 17, 18, 19, 20 

### IMPORTANT

- Cutting fluid such as WD40 or GM P/N 1052864 is necessary for all drilling and tapping operations!
- A drill motor is recommended for all drilling and counterboring operations.
- Driver oil J 42385-110 must be used on the insert driver.
- After each cutting operation clean out chips using compressed air.
- Stop collars on step drills J 42385-101 and J 42385-105 are not adjustable! Do not adjust! Adjusting these collars will result in incorrect hole depths and possible engine damage!
- Do not allow metal chips or shavings to enter the engine assembly. Cover and clean components as necessary.

### ! WARNING

Safety glasses must be worn at all times when using this kit.

## INSTRUCTIONS

**NOTE:** Head bolt and main bolt repair operations are similar, both may not be shown.

### Step 1

Place largest hole in fixture plate -301 over the cylinder head hole to be repaired.

**-OR-**

### Step 2

Place the largest hole in fixture plate -306 over the main cap bolt hole to be repaired. **NOTE:** It may be necessary to rotate fixture plate upside down for certain holes.

### Step 3

Place bushing in fixture and alignment pin through the bushing and into the hole. Do not force the pin in place. Use appropriate attachment bolts to secure the fixture using short bolts in shallow holes. Tighten to (15 Ft/Lb, 20 Nm Max.) Do not use an impact wrench!

### Step 4

Use the appropriate sleeve (-315 or -316) if repairing a shallow hole. Install onto drill and against stop collar.

### Step 5

Drill out damaged threads using step drill until stop collar contacts the bushing. This will require removing the drill and bushing several times to clear chips. **Note:** If bushing turns while drilling, remove drill and bushing and clean chips from each component.

### Step 6

Using the tap and tap handle, tap through the bushing until the appropriate groove on the tap aligns with the top of the bushing. **Note:** On shallow holes align the tap groove closest to the threads with the top of the bushing. This will require removing the tap and bushing several times to clear chips.

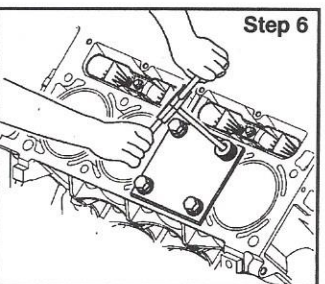
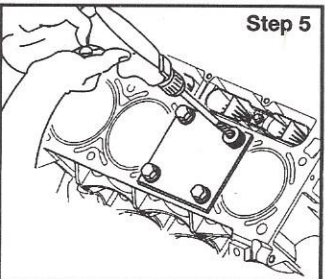
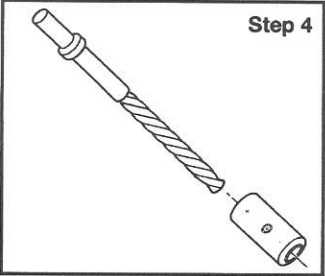
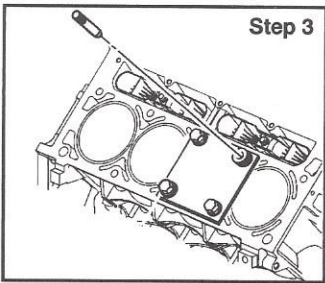
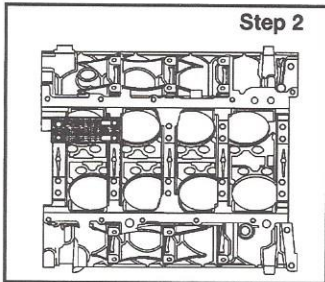
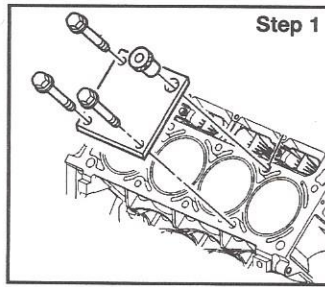

### Step 7

Remove bushing and cylinder head fixture -301. Do not remove the main cap fixture plate and bushing. Clean all chips from the hole using spray cleaner GM P/N 12346139 or P/N 12377981 and compressed air. The hole must be clean and dry prior to insert installation.

### Step 8

Oil threads of the insert driver using J 42385-110. Do not use WD40.

### Step 9

Thread an insert onto the driver.

### Step 10

Apply a small amount of Loctite® #277 to the bottom outside threads of the insert.

### Step 11

Install the head bolt thread insert into the prepared hole. Rotate the driver until the groove on the driver aligns with the top of the cylinder block. **NOTE:** On the shallower holes, align the groove on the driver closest to the threads with the cylinder block deck.

### Step 12

Install the main cap thread insert through the bushing and into the prepared hole. Rotate the driver until the groove on the driver (1 or 2) aligns with the top of the bushing. **NOTE:** On the shallower holes, align the groove on the driver (2) closest to the threads with the top of the bushing.

When the head of the insert is seated, the driver will tighten up before screwing completely through the insert. This is normal since the bottom threads of the insert are being formed and mechanically locking the insert into the hole. Use a little more force and rotate the driver through the insert until the appropriate mark on the driver aligns with the cylinder head deck or bushing. See note below.

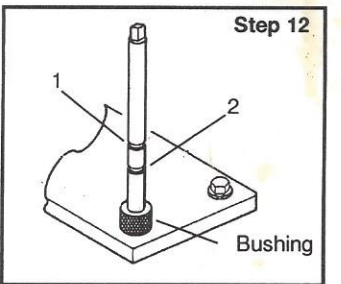
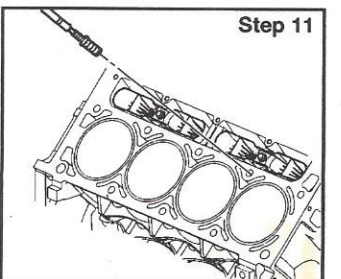
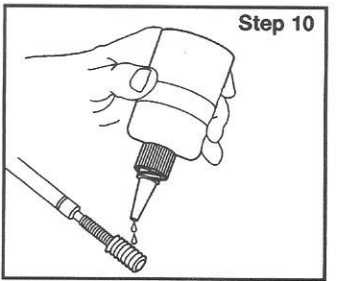
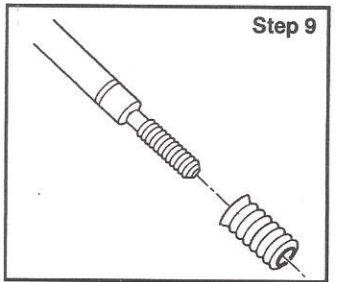
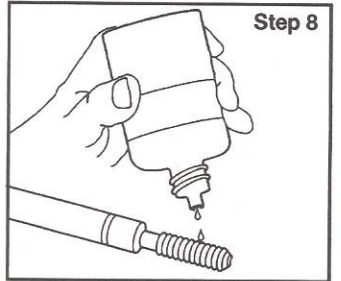
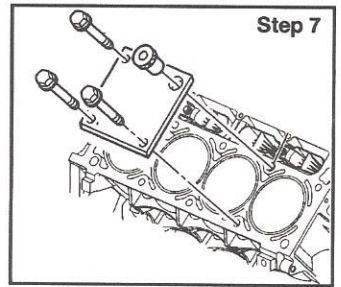

## NOTE:

To check for correct installation, measure deck surface to top of insert.

**MAIN**  
1.5mm (shallow hole)  
20.5mm (deep hole)

**HEAD**  
30mm (shallow hole)  
85mm (deep hole)